

SPECIAL EQUIPMENT ASY-DRAINER 80 / VACU-DRAINER 80 / VACU 80

EN. Waste oil gravity/suction drainers.

The wheels-mounted waste oil drainers are especially suitable to be used under lift and in all situations in which recovery of engine/transmission/differential oil is performed by gravity flow.

The high capacity collector, which features a filter drain grill, is height adjustable and mounted at the side of the 80 l recovery tank, which is emptied pneumatically by means of a special compressed air inlet valve.

The model with air-operated suction, which is equipped with a transparent level gauge, also allows oil to be retrieved directly from the engine using suction probes.

ES. Recuperadores/aspiradores neumáticos de aceite usado.

Estos recuperadores de aceite están provistos de ruedas y son especialmente adecuados para emplearlos debajo de un elevador de carro, en situaciones en las cuales el aceite del motor, del cambio o del diferencial se descarga por gravedad.

El colector, de alta capacidad y dotado de rejilla escurridora, se regula en altura y está montado junto al depósito de 80 l. El depósito se vacía por acción neumática mediante una válvula que introduce aire comprimido.

El modelo con aspiración neumática recupera el aceite directamente del motor mediante sondas de aspiración y está dotado de un visor transparente.

RU. Тележечные регенераторы отработанного масла в первую очередь предназначены для применения под мостом, при выполнении всех операций, при которых рекуперация масла мотора/передачи/дифференциала происходит гравитационным методом. Резервуар высокой вместимости с решеткой для стока фильтров и регулируемой высотой установлен сбоку приемного бака емкостью 80 л. Слив данного бака происходит пневматически с помощью специального входного клапана для сжатого воздуха.

Кроме того, модель с пневматическим всасыванием позволяет выполнять рекуперацию масла прямо из мотора с помощью аспирационных щупов и имеет прозрачное смотровое приспособление.

DIMENSIONS

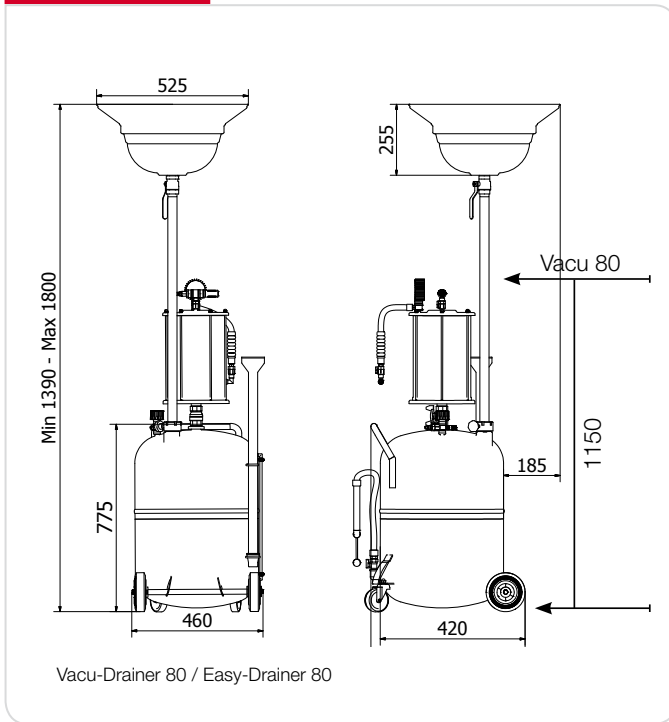

Vacu-Drainer 80 / Easy-Drainer 80



Vacu-Drainer 80

Easy-Drainer 80

PRODUCTS' RANGE WEIGHT AND PACKAGING

Code	Weight		Packaging		
	kg	lbs	mm	inch	pcs/box
F00215A20	27,5	60,6	480x520x1210	18,1x18,1x39,8	1
F00215A30	32,5	71,6	480x520x1210	18,8x20,8x47,6	1
F00215A40	28,2	62,2	480x480x1030	18,8x18,9x40,5	1

Tank capacity

80 lit
(21,1 gal)



Easy-Drainer 80



Vacu-Drainer 80



Vacu 80

FEATURES

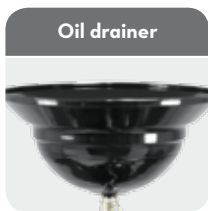

Oil drainer

12 lit Capacity



Tank level indicator



Inflating valve + gauge

CE system 0,5 bar



Transparent recovery viewer

(Vacu-drainer 80 + Vacu 80 ONLY)



Vacuum gauge

(Vacu-drainer 80 + Vacu 80 ONLY)



Suction probes

(Vacu-drainer 80 + Vacu 80 ONLY)

PRODUCTS' RANGE TECHNICAL DATA

Code	Description	Fluid	Tank capacity		Tank level gauge	Bowl Ø 520 mm capacity	Discharge safety valve	Flexible probes kit	Discharging pipe	Suction pipe	Transparent viewer
			lit	gal							
F00215A20	Easy-Drainer 80	☐	80	21,1	Yes	12	Yes	No	2	No	No
F00215A30	Vacu-Drainer 80	☐	80	21,1	Yes	12	Yes	Yes	2	2	9
F00215A40	Vacu 80	☐	80	21,1	Yes	No	Yes	Yes	2	2	9

DISPENSERS

PUMPS

METERS

NOZZLE METERS

NOZZLE

SPECIAL EQUIPMENTS

FLUID MONITORING

HOSE REEL

FILTERING

ACCESSORIES